RECONSTRUCTION AND REPLACEMENT OF EARTHQUAKE DAMAGED MASONRY CHIMNEYS

This Los Angeles Department of Building and Safety (LADBS) standard plan provides prescriptive details to facilitate the reconstruction of an earthquake damaged masonry chimney using a new factory-built metal chimney or replacement of an earthquake damaged masonry firebox and chimney with a new masonry firebox and a factory-built metal chimney. The two methods are titled:

1. **RECONSTRUCTION OF EARTHQUAKE DAMAGED MASONRY CHIMNEY USING A NEW FACTORY-BUILT METAL CHIMNEY; and,**
2. **REPLACEMENT OF EARTHQUAKE DAMAGED MASONRY FIREBOX AND CHIMNEY WITH A NEW MASONRY FIREBOX AND A FACTORY-BUILT METAL CHIMNEY.**

Masonry chimneys are required to be designed in accordance with LAMC Section 91.3102.7 and must be either free standing or supported from the attached structure. Reconstruction or replacement of a damaged masonry chimney **is not allowed** with masonry unless completely removed, redesigned and constructed to current code requirements. This will require structural plans and calculations prepared by a civil engineer, structural engineer, or architect licensed by the State of California. These structural plans and calculations must be reviewed prior to permit issuance at the plan check counter of a LADBS Construction Services Center.

A building permit is required for either method. Method 1, reconstruction of the chimney, does not require plan check and the permit can be issued at a LADBS Construction Services Center or electronically by facsimile or through the internet (www.ladbs.org). Method 2, replacement of the firebox and chimney, does require plan check and the permit can only be issued at a LADBS Construction Services Center. For Method 2, provide the following indelible plans:

1. A plot plan drawn to scale showing the shape of the parcel, the perimeter of the building, and the setback of the building and fireplace perimeter to all parcel boundaries.
2. A floor plan drawn to a scale of 1/4 inch to 1 foot showing the existing use of each room adjacent to the fireplace.

RECONSTRUCTION OF EARTHQUAKE DAMAGED MASONRY CHIMNEY USING A NEW FACTORY-BUILT METAL CHIMNEY

Unreinforced Masonry Chimneys

Damaged unreinforced masonry chimneys shall be repaired by:

- C Utilizing **Section "B"** of this standard.
- C Removal down to the throat of the nearest undamaged firebox.
- C Construction of a concrete bond beam on top of the remaining firebox.
- C The concrete bond beam need not be anchored to the building.

Reinforced Masonry Chimneys

Reinforced masonry chimneys shall be repaired based on the following damage cases:

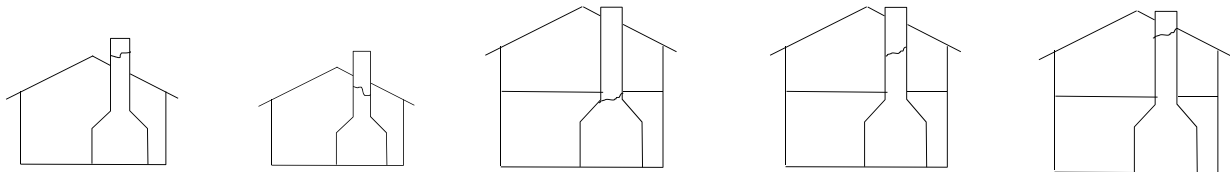

CASE 1

CASE 2

CASE 3

CASE 4a

CASE 4b

CASE 1 - Damaged above the Ceiling/Roof Line

- **Section "A"** of this standard shall be utilized for repair.
- C The old reinforced masonry shall be removed down to the roof line.
- C A concrete bond beam shall be constructed on top of the remaining reinforced masonry chimney.
- C The concrete bond beam shall be anchored to the building.

CASE 2 - Damaged below the Ceiling/Roof Line of a One-Story Building

- C **Section "B"** of this standard shall be utilized for repair.
- C The old masonry shall be removed down to the throat of the firebox.
- C A concrete bond beam shall be constructed on top of the remaining firebox.
- C The concrete bond beam need not be anchored to the building.

CASE 3 - Damaged below the Ceiling Line of the First Floor of a Two-Story Building

- C **Section "C"** of this standard shall be utilized for repair.
- C The old masonry shall be removed down to the throat of the firebox.
- C A concrete bond beam shall be constructed on top of the remaining firebox.
- C The concrete bond beam need not be anchored to the building.

CASE 4a - Damaged Between the Ceiling/Roof Line and the Second Floor of a Two-Story Building

- C **Section "D"** of this standard shall be utilized for repair.
- C The old reinforced masonry shall be removed down to the second floor-line.
- C A concrete bond beam shall be constructed on top of the remaining masonry chimney.
- C The concrete bond beam shall be anchored to the second floor diaphragm.

CASE 4b - Damaged Between the Ceiling/Roof Line and the Second Floor of a Two-Story Building (Firebox Located at Second Floor)

- C **Section "B"** of this standard shall be utilized for repair.
- C The old masonry shall be removed down to the throat of the second floor firebox.
- C The remaining portion below the second floor is undamaged.
- C A concrete bond beam shall be constructed on top of the remaining firebox.
- C The concrete bond beam need not be anchored to the building.

REPLACEMENT OF EARTHQUAKE DAMAGED MASONRY FIREBOX AND CHIMNEY WITH A NEW MASONRY FIREBOX AND A FACTORY-BUILT METAL CHIMNEY

Metal chimney/masonry fireplace combinations for new construction are allowed provided the firebox construction complies with LAMC Section 91.3102.7 for new construction and the bond beam firebox transition does not extend more than seven (7) feet above grade and the construction complies with the details in this standard.

The prescriptive details provide that the concrete footing/masonry firebox combination is self supporting and does not rely on or provide support to the building. The following conditions shall apply:

- C All mortar and grout shall be sack mix only; no on site mixing of cement, sand and lime shall be permitted.
- C Reinforcing steel shall be minimum grade 40 with main vertical bars continuous from footing to bond beam.
- C Tack welding shall not be permitted.
- C All voids within the masonry shall be solidly grouted.

CHIMNEY SPECIFICATIONS

1. All factory-built chimney assemblies (pipes, spark arrester, and anchor plates) shall be tested to U.L. Standard 103 by a testing laboratory approved by the City of Los Angeles.
2. Chimneys shall be listed by the testing laboratory as "Residential Type and Building Heating Appliance Chimney" when used for wood burning fireplaces. Chimneys listed as only a "Building Heating Appliance Chimney" are for installation in other than one-or-two-family dwellings.
3. Chimneys for fireplaces with a closed air-tight combustion chamber shall be designated "Type HT".
4. Factory-built chimney assemblies shall be used and installed in accordance with the terms of their listing and the manufacturer's instructions.
5. The masonry to metal chimney transition shall be accomplished through the use of a 12 gage steel adapter cone which is imbedded in the concrete bond beam as detailed in this standard plan. A "paroc" basalt insulation gasket shall be installed between the adapter cone flange and the metal chimney anchor plate.

ADDITIONAL REQUIREMENTS

Maximum Height

The height of the chimney above the roof shall be limited to ten feet under this standard.

Diameter of Metal Chimney

The diameter of the factory-built metal chimney assembly shall be based upon the manufacturer's specifications and instructions for the least dimension of the existing flue, whichever is greater.

Draft Stop

A draft stop consisting of drywall or plywood shall be provided to separate the chase from wood members of the existing building.

Inspection

The firebox, chimney, and other undamaged areas MUST be carefully visually inspected for cracks or voids, which may permit the access of flames or smoke to the surrounding wood framing, prior to any construction.

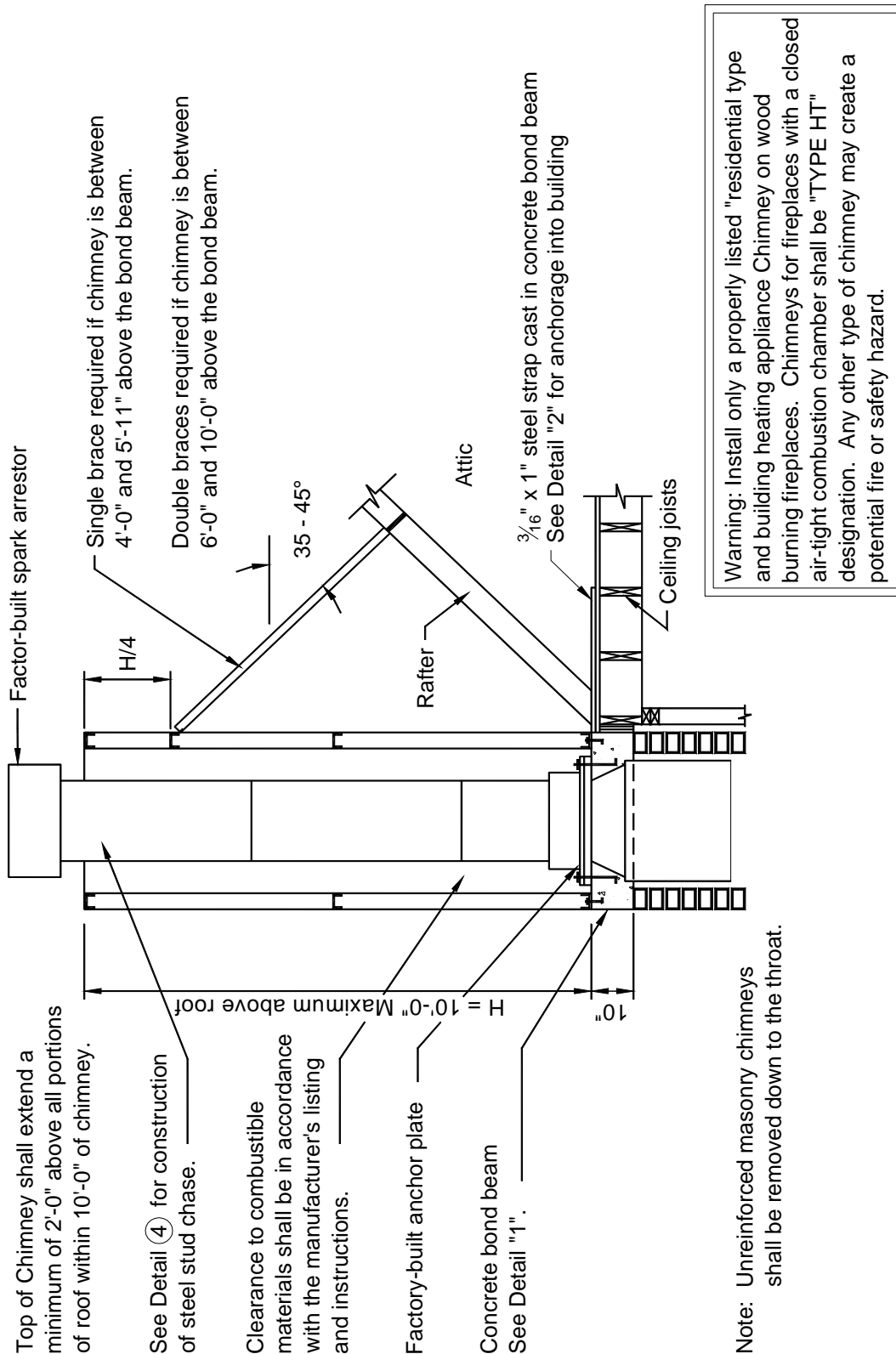

SECTION A
Chimney Damage Above Roof Line

Top of chimney shall extend a minimum of 2'-0" above all portions of roof within 10'-0" of chimney.

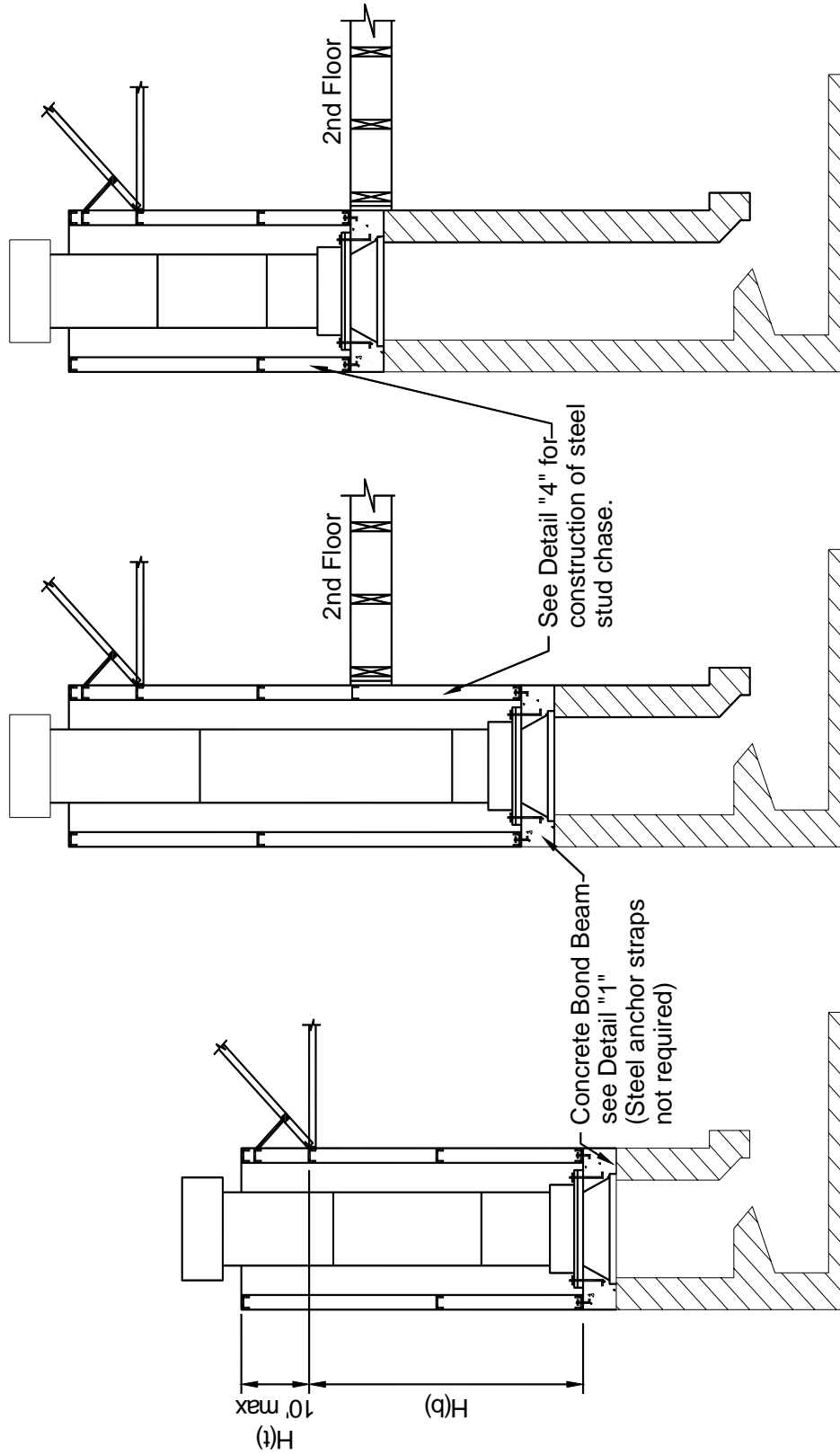

SECTION D

SECTION C

SECTION B

As a covered entity under Title II of the Americans with Disabilities Act, the City of Los Angeles does not discriminate on the basis of disability and, upon request, will provide reasonable accommodation to ensure equal access to its programs, services and activities. For efficient handling of information internally and in the internet, conversion to this new format of code related and administrative information bulletins including MGD and RGA that were previously issued will allow flexibility and timely distribution of information to the public.

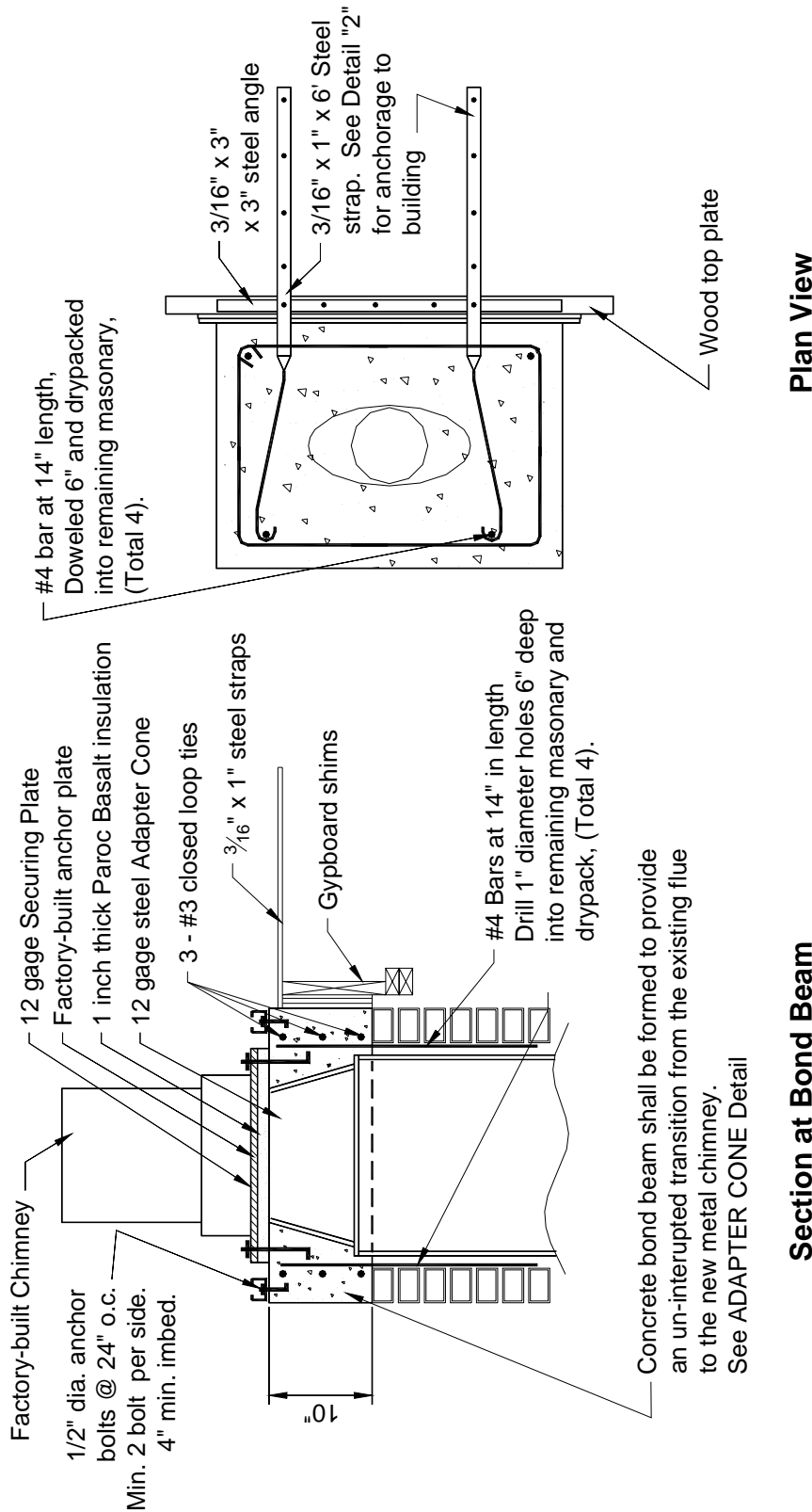

DETAIL 1

Section at Bond Beam

As a covered entity under Title II of the Americans with Disabilities Act, the City of Los Angeles does not discriminate on the basis of disability and, upon request, will provide reasonable accommodation to ensure equal access to its programs, services and activities. For efficient handling of information internally and in the internet, conversion to this new format of code related and administrative information bulletins including MGD and RGA that were previously issued will allow flexibility and timely distribution of information to the public.

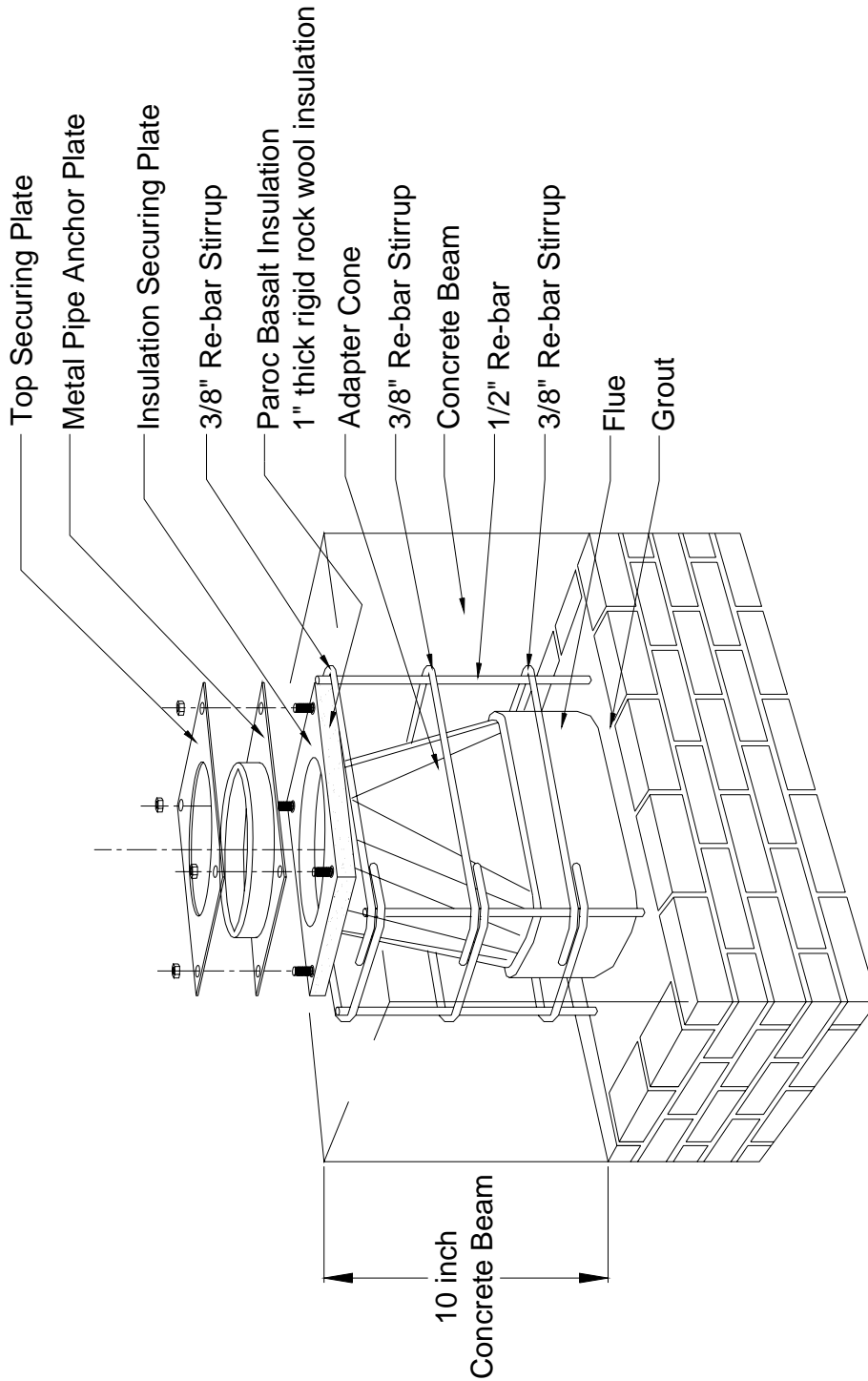

Adapter Kit

DETAIL A
**TRANSFORMATION FROM MASONRY
FIREPLACE TO METAL CHIMNEY**

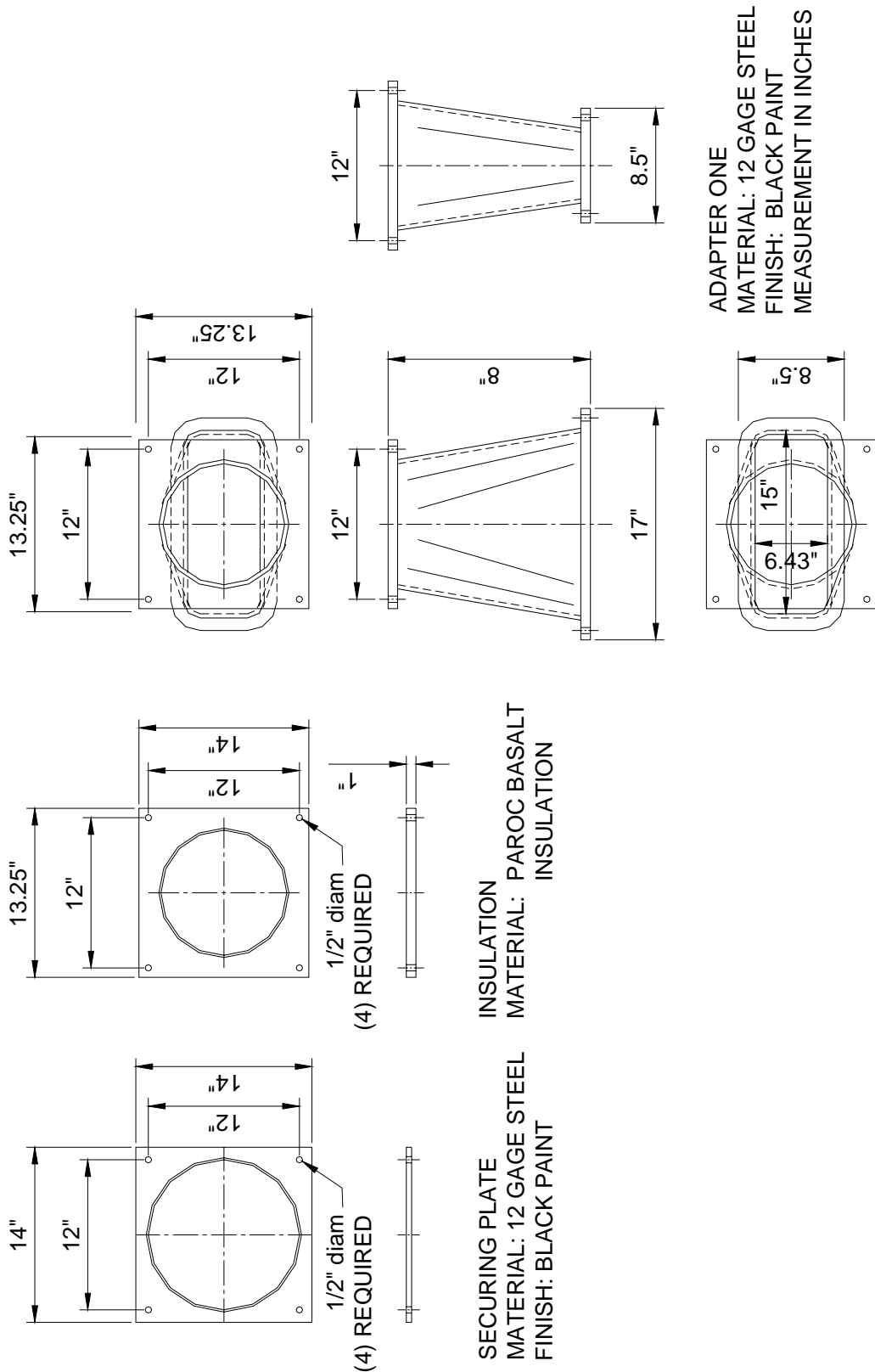

ADAPTER CONE

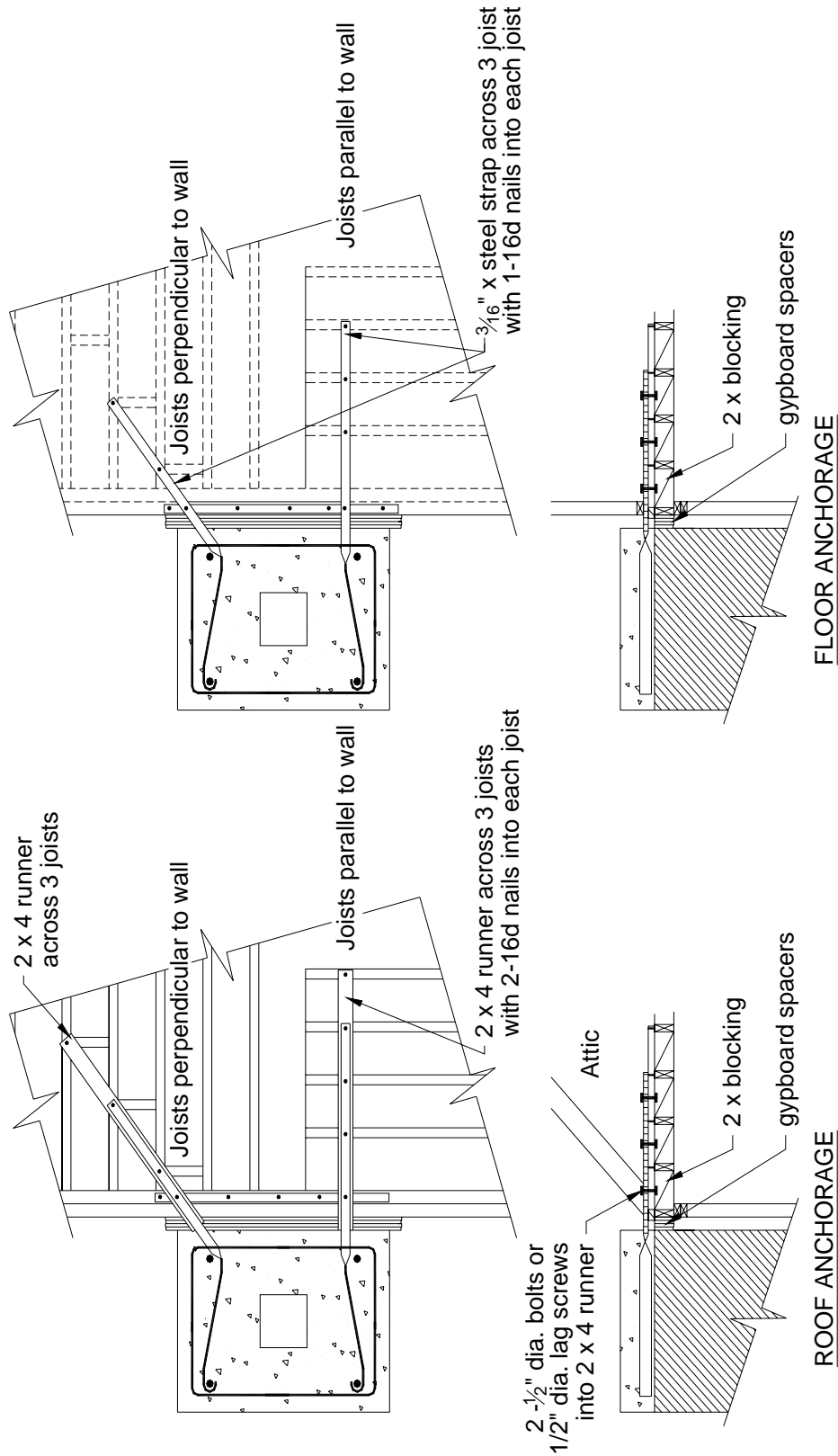

As a covered entity under Title II of the Americans with Disabilities Act, the City of Los Angeles does not discriminate on the basis of disability and, upon request, will provide reasonable accommodation to ensure equal access to its programs, services and activities. For efficient handling of information internally and in the internet, conversion to this new format of code related and administrative information bulletins including MGD and RGA that were previously issued will allow flexibility and timely distribution of information to the public.

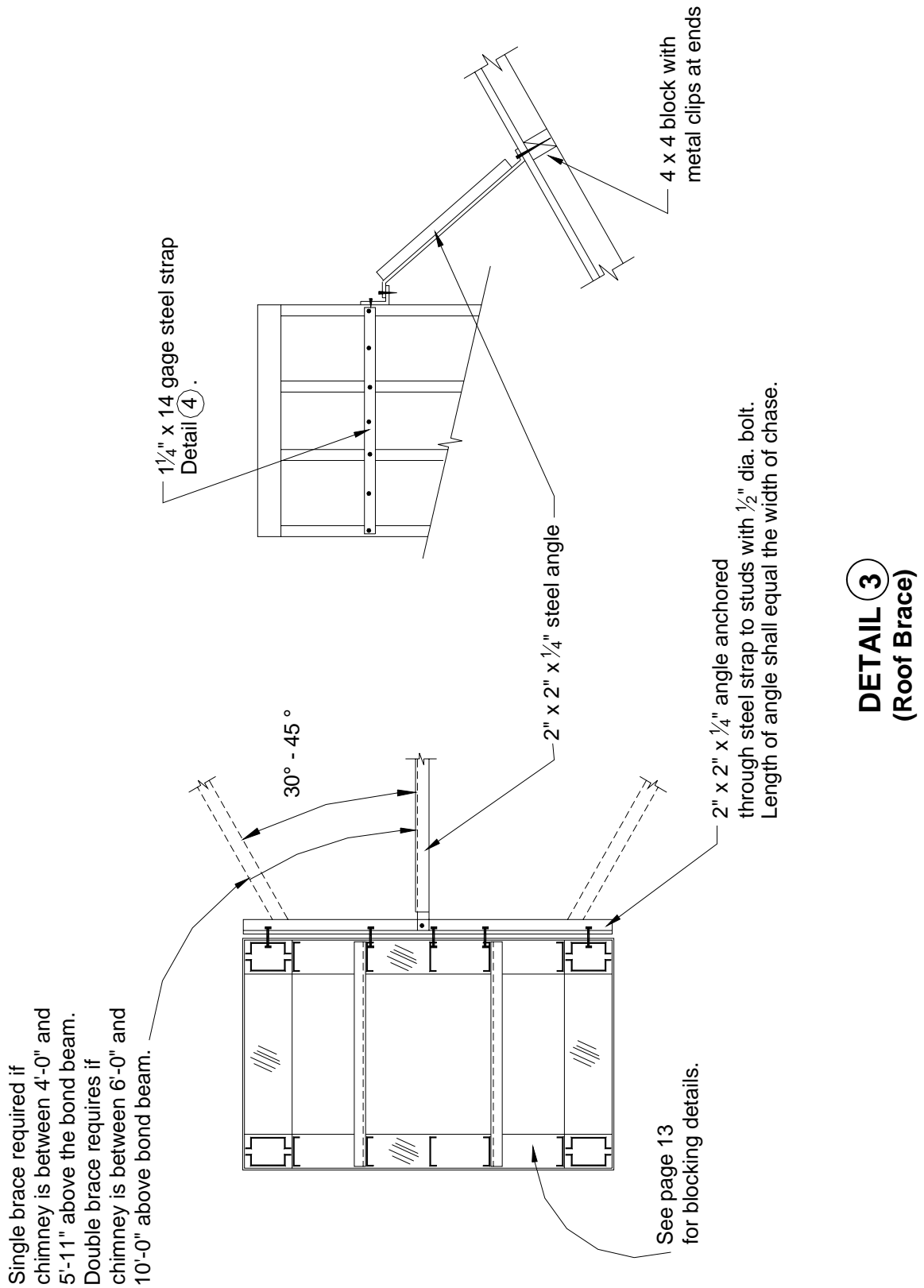

DETAIL 2
(Concrete Bond Beam Anchorage Into Building)



As a covered entity under Title II of the Americans with Disabilities Act, the City of Los Angeles does not discriminate on the basis of disability and, upon request, will provide reasonable accommodation to ensure equal access to its programs, services and activities. For efficient handling of information internally and in the internet, conversion to this new format of code related and administrative information bulletins including MGD and RGA that were previously issued will allow flexibility and timely distribution of information to the public.

Covering Material	Fatesners
Laths for stucco	No. 8 x 5/8" sheet Metal screws at 6" o.c. 
Plywood	No. 6 Bugle head screws at 6" o.c. at chase and 12" o.c. at interior edges and fields. 

STEEL STUDS SPECIFICATIONS:

All steel studs shall be either galvanized or factory painted "C" type stud.

Minimum 18 gage
Minimum width 3 1/2"
Minimum Fy = 33 ksi

COVERING

Steel stud chase may be covered with stucco or adhered veneer.

Note: Adhered veneer shall be a max. 1" with plywood backing (3/8" min.) and shall be installed per division 30 of the L.A. buidling code.

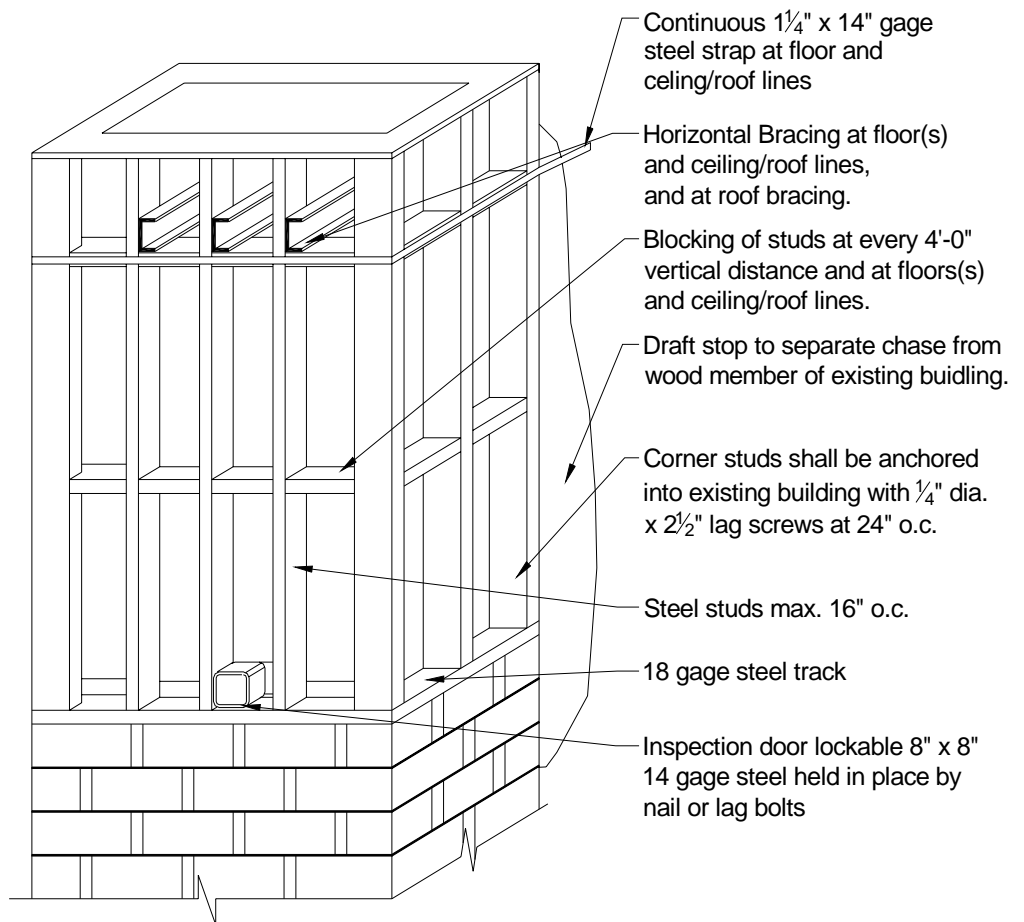

Detail 4

As a covered entity under Title II of the Americans with Disabilities Act, the City of Los Angeles does not discriminate on the basis of disability and, upon request, will provide reasonable accommodation to ensure equal access to its programs, services and activities. For efficient handling of information internally and in the internet, conversion to this new format of code related and administrative information bulletins including MGD and RGA that were previously issued will allow flexibility and timely distribution of information to the public.

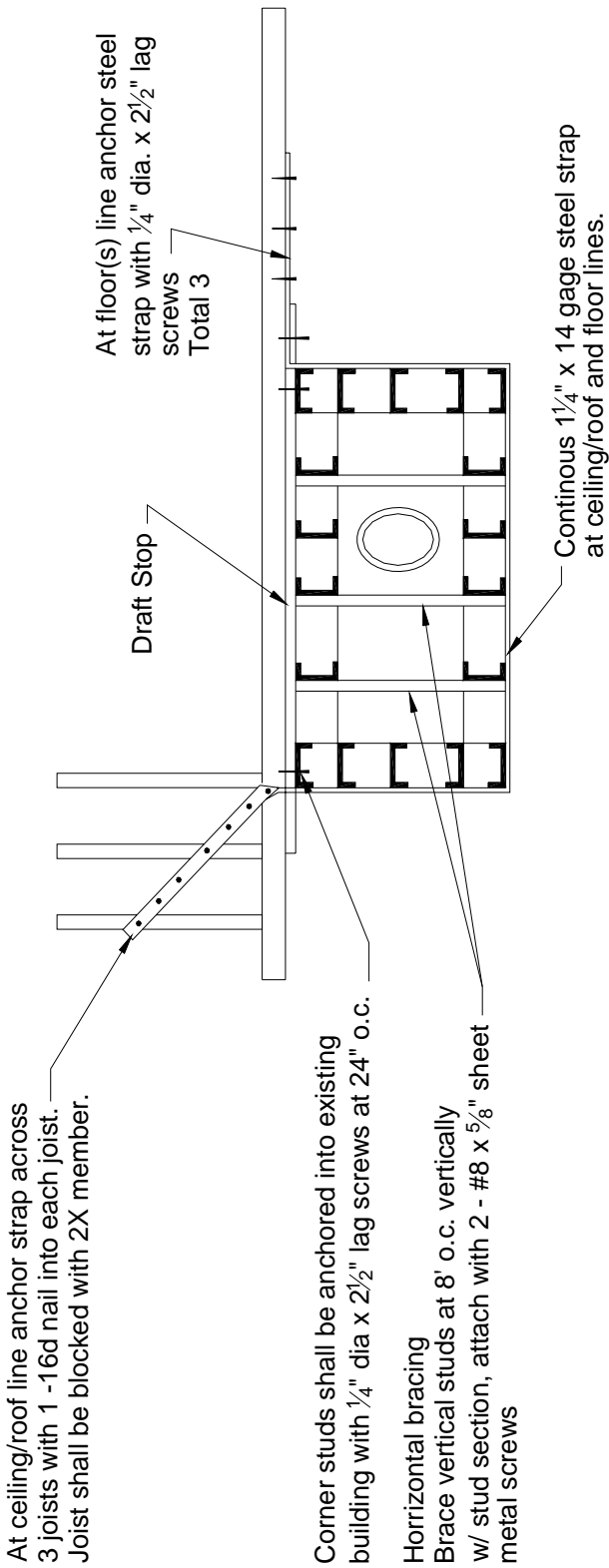

Strapping & Bracing Detail
@ Ceiling/Roof and Floors

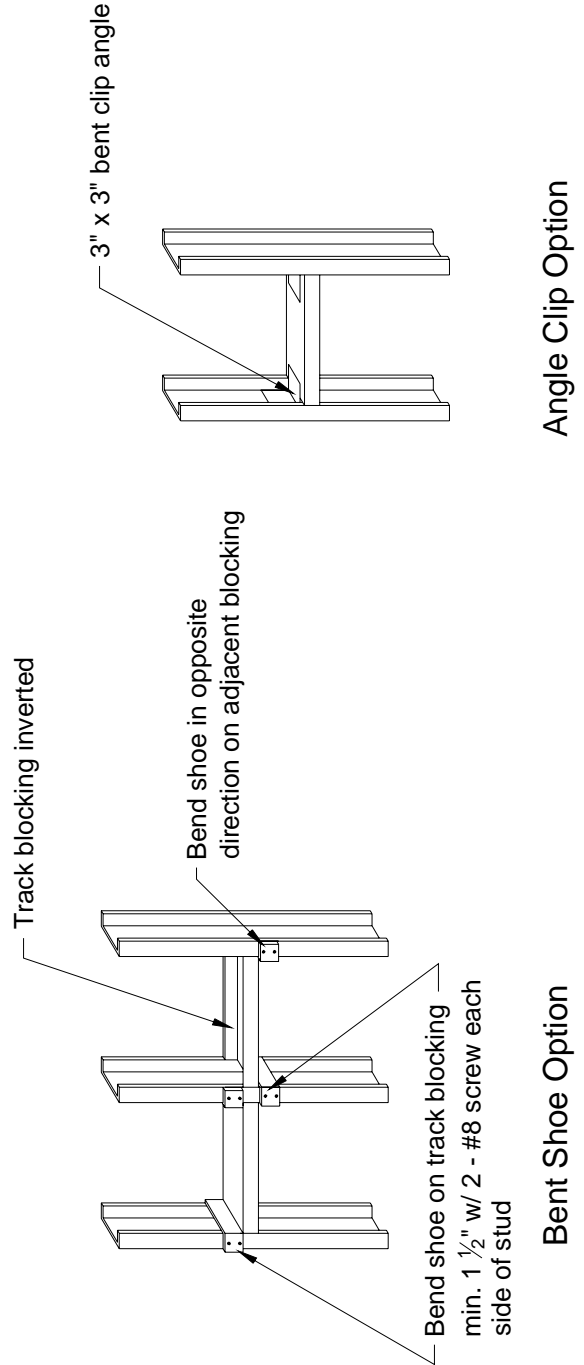

Blocking Details

Inspection Requirements

The permit holder or his agent shall notify the Department when the chimney is ready for each of the following inspections:

1. Concrete Bond Beam: When the form and required reinforcing steel are in place but before any concrete is poured.
2. Framing: When all members including but not limited to bracing, blocking, metal chimney or flashing are in place, but before any covering is in place.
3. Stucco: When the backing and lath is in place ready for stucco.
4. Final: When the chimney is completed.

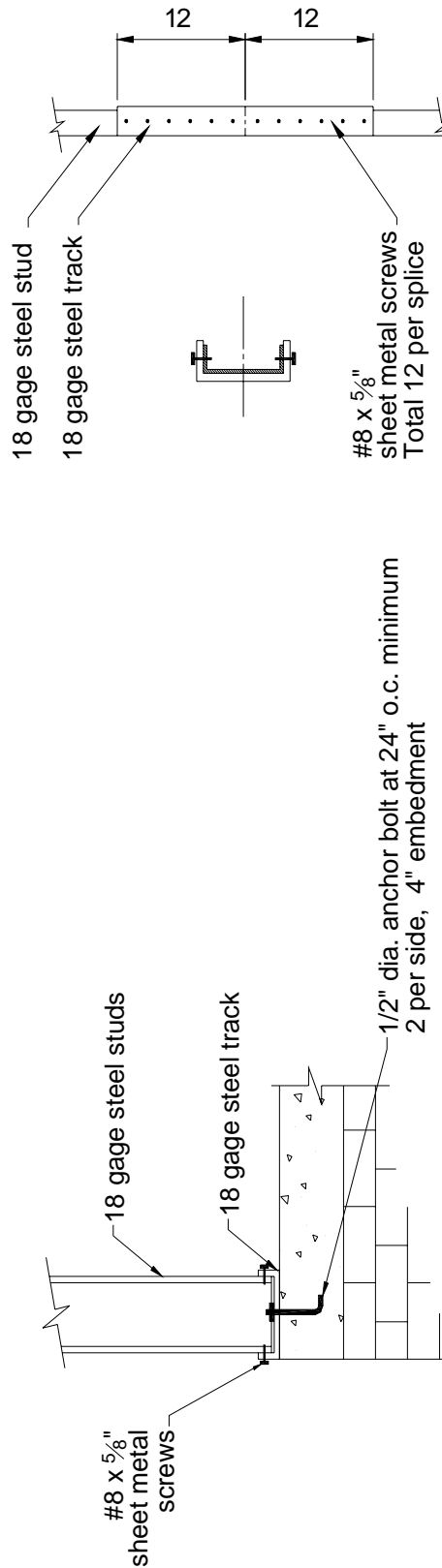

Track Detail

Splice Detail

Splice shall be staggered a minimum of 12" vertically.
Maximum one splice per stud.

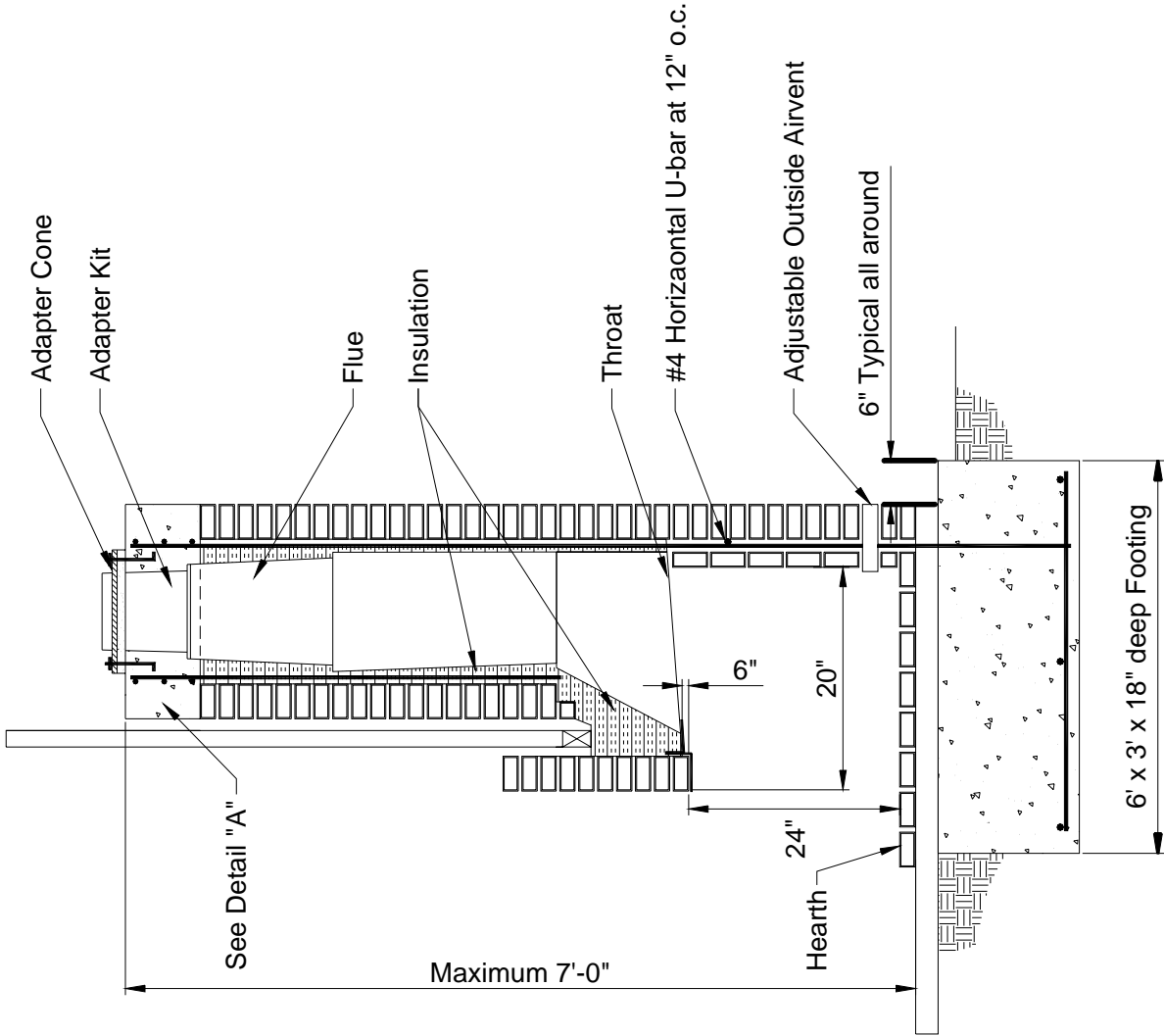

New Firebox - Cross Section Typical 36" Fireplace

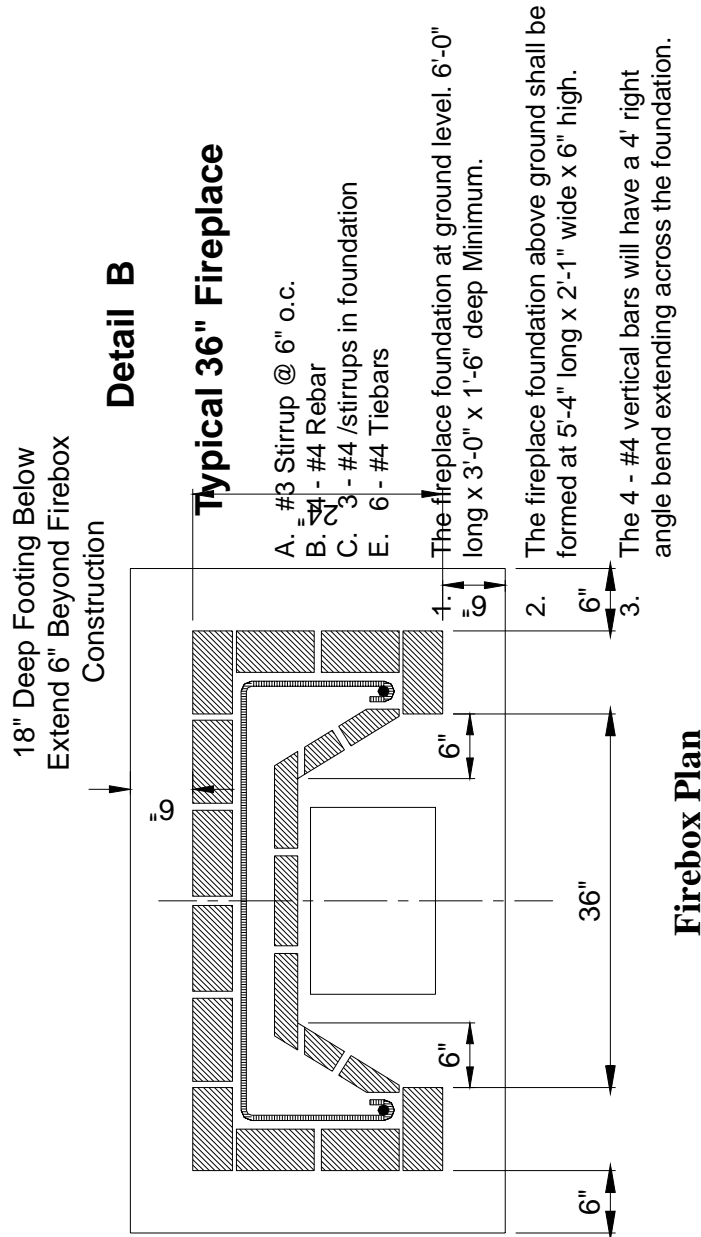

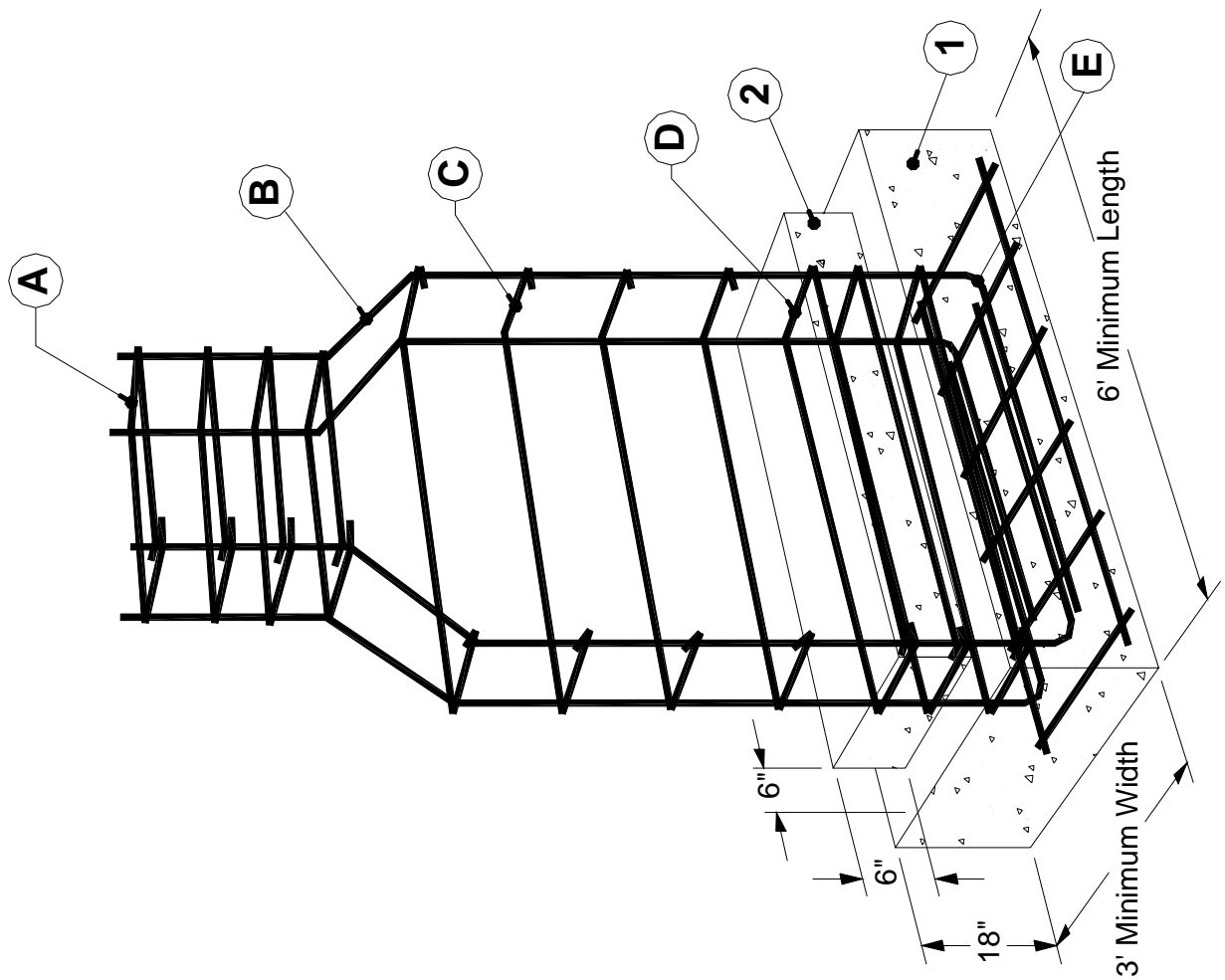

As a covered entity under Title II of the Americans with Disabilities Act, the City of Los Angeles does not discriminate on the basis of disability and, upon request, will provide reasonable accommodation to ensure equal access to its programs, services and activities. For efficient handling of information internally and in the internet, conversion to this new format of code related and administrative information bulletins including MGD and RGA that were previously issued will allow flexibility and timely distribution of information to the public.